



series 2801

BOOM TRUCKS

features

- 28 Ton (24,4 mton) Capacity
- 4-Section 92' (28 m) Proportional Boom
- 149' 1" (45,4 m) Maximum Tip Height
- 103' (31,4 m) Maximum Main Boom Tip Height
- 2-Section 26' (7,9 m) to 46' (14 m) Jib (with LMI only)
- 2-Speed Planetary Hoist with Grooved Drum and Negative Draft Flange
- Hydraulic Capacity Alert Warning System with Function Shut-off
- Load Moment Indicating (capacity alert) System Option. Equipped with internal boom length cable, crane circuit status LEDs and function shutoff
- 21' 6" (6,6 m) A-Frame Outriggers
- 13' 11" (4,23 m) Out-and-Down Rear Stabilizers
- Front bumper stabilizer with auto-retract feature for a 360° area of operation (option).
- Rugged, Weatherproof, Connectorized Electrical System
- Removable Boom Rest
- System Pressure Gauge
- Clamp-On Mounting
- Manitek UPTIME Comprehensive Support



product guide

series 2801

GENERAL SPECIFICATIONS

BOOM

Booms - Inverted T-cross section, 4-section telescoping type, extended and retracted proportionally by double-acting hydraulic cylinder and cable-crowd system. Easily replaceable and adjustable high-density nylon slide pads.

2892C - 4-Section 28' (8.5 m) to 92' (28,0 m). Maximum main boom tip height 103' (31,4 m). 2-Section, 26' (7,9 m) to 46' (14,0 m) jib. Maximum tip height 149' 1" (45,4 m) (Jib available with LMI option only).

Quick Reeve Boom Point - Two high-density nylon load sheaves mounted on heavy-duty roller bearings. Two removable pin-type rope guards.

Boom Elevation - Double-acting hydraulic cylinder. Working range from 9° below horizontal to 80° above.

Load Hook - 5-ton (4,5 mton) capacity hook with heavy-duty swivel and weight is provided for single-line operation.

HOIST

Maximum theoretical line speed 300 fpm (91,4 mpm). Maximum theoretical bottom-layer line pull 11,500 lb (5 216 kg). Two-speed planetary reducer. Spring applied, pressure-released internal brake.

SWING SYSTEM

Externally mounted, double-reduction planetary driven by hydraulic motor. Maximum theoretical swing speed 1.5 rpm. Spring-applied, pressure-released parking brake. Ball-bearing swing circle with external gear. 372° non-continuous rotation.

OUTRIGGERS

A-Frame link type with double-acting hydraulic cylinders operated independently for precise leveling. Bubble level located near outrigger controls.

STABILIZERS

Stabilizers - Underframe out-and-down type with double-acting hydraulic cylinders operated independently for precise leveling.

Front Bumper stabilizer (option) – Single stabilizer mounted at the front of the truck for 360° area of operation. Stabilizer cylinder protected by auto-retract feature to prevent drive away damage. This option may require front frame extensions-consult factory.

MOUNTING

Mounting - Pedestal and subframe are mounted to chassis by threaded rods and clamp plates. No welding, drilling, or bolting to truck frame is required.

Subframe - Torsion resistant, rigid 4-plate design. Mounted under crane full length of truck frame.

Rear Underride Protection - Supplied on factory mounted cranes. Fabricated structure mounted under rear of bed. Complies with Bureau of Motor Carrier Safety Standard 393.86.

Boom Rest - Heavy-duty fabrication. Easily removed to simplify loading and unloading truck deck.

CONTROL SYSTEM

Dual operator platforms are equipped with four single-lever crane controls arranged to ANSI B30.5 standards. Fully proportional control valves and system pressure gauge. Each station also includes outrigger and stabilizer controls, engine start/stop, foot throttle, signal horn, boom-angle indicator, bubble levels, load chart and range diagram.

HYDRAULICS

Hydraulic System - A 3-section gear pump direct-mounted to power take-off on truck transmission provides 32 gpm (121 lpm) to the hoist, 10 gpm (38 lpm) to the swing and 21 gpm (79,5 lpm) to the remaining crane functions. 70-gallon (265-liter) baffled reservoir with strainer and 25-micron filter in the return lines. Ball-type shutoff valve and strainer are provided in suction line. All fittings are ORS face and SAE O-ring type.

Hydraulic Cylinders - All load-holding cylinders are equipped with integral holding valves.

WARNING SYSTEMS

HYCAS (Standard) - Senses boom hoist cylinder pressure and boom length. Audio warning indicates overload condition; crane function shutoff feature prevents continuing overload.

Load Moment Indicator "LMI" (Option) – CAN bus system maximizes expansion capabilities. Senses boom hoist cylinder pressure, boom length and boom angle. Audio-visual warning indicates overload conditions; crane function shutoff feature prevents continuing overload. Internal boom length cable. Operator can access all load conditions via display at the operator station. Upper and lowerboom angle alarms can be set by the operator. Equipped with crane circuits status LEDs in electrical system.

Radio Anti-Two-Block System - Audible warning and shutoff functions prevent hook from contacting boom point. Wireless system minimized downtime typically associated with damaged cables in wired systems.

Back-Up Alarm - Supplied on factory-mounted cranes, electronic audible motion alarm activated when truck transmission is in reverse gear.

GENERAL

Electrical - State-of-the-art, weather-resistant components throughout. Hermetically sealed power in relays. Designed to withstand high pressure washing and varying climates.

Design/Welding - Design conforms to ANSI B30.5. Welding conforms to AWS D1.1. Tested to SAE 1063 and SAE 765.

Manuals - Operator, service and parts manuals depict correct crane operation, maintenance procedures and parts listing.

Warranty - 12-month warranty covers parts and labor resulting from defects in material and workmanship.

* In order to ensure continuous improvement, specifications may change without notice.

OAH Overall Height
 CT Cab to Tandem
 CA Cab to Axle
 WB Wheel Base
 OAL Overall Length
 BBC Bumper to Back of Cab
 AF Afterframe

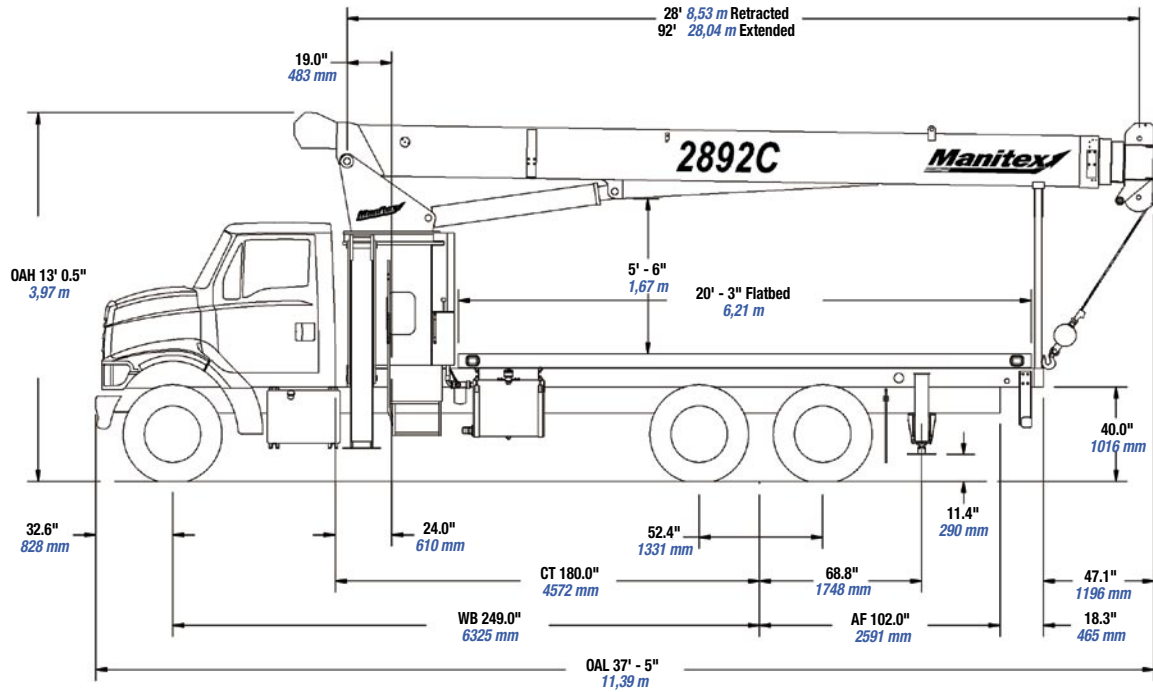

CHASSIS DATA	2892C
Wheelbase (WB)	249" 6 426 mm
Cab to Tandem (CT)	180" 4 527 mm
After Frame (AF)	102" 2 591 mm
Frame Section Modulus	23.0 in³ 110,000 psi 758 422 kPa
Frame Section Modulus for 360° rotation (minimum)	28.0 in³ 110,000 psi 758 422 kPa
Front Axle Gross Weight Rating	16,000 lb 7 257 kg
Rear Axle Gross Weight Rating	34,000 lb 15 422 kg
Minimum Truck Axle Weight - Front*	8,500 lb 3 855 kg
Minimum Truck Axle Weight - Back*	8150 lb 3 697 kg
Nominal Frame Width	34" 664 mm

*Minimum chassis weight is required to meet 85% stability requirements.
Chassis data is general - not for engineering. Some dimensions depend on truck selection.

WEIGHTS	2892C
Total Crane - Standard	20,452 lb 9 292 kg
Total Crane - Out-and-Down Outriggers (Out-and-Down outrigger configuration only available on LMI unit)	24,612 lb 11 184 kg
20' (6,10 m) Flat Bed - Standard Outriggers	1,840 lb 835 kg
22' (6,71 m) Flat Bed - Out-and-Down Outriggers	2,000 lb 907 kg
26' (7,93 m) Fixed Length Jib	832 lb 377 kg
26' (7,92 m) to 46' (14,02 m) Telescopic Jib	1,226 lb 556 kg

MAXIMUM TIP HEIGHT	2892C
Configuration	Boom 92' 28,0 m
Extended Boom	103' 31,4 m
Fixed or Retracted Jib	129' 4" 39,4 m
Extended Jib	149' 45,4 m

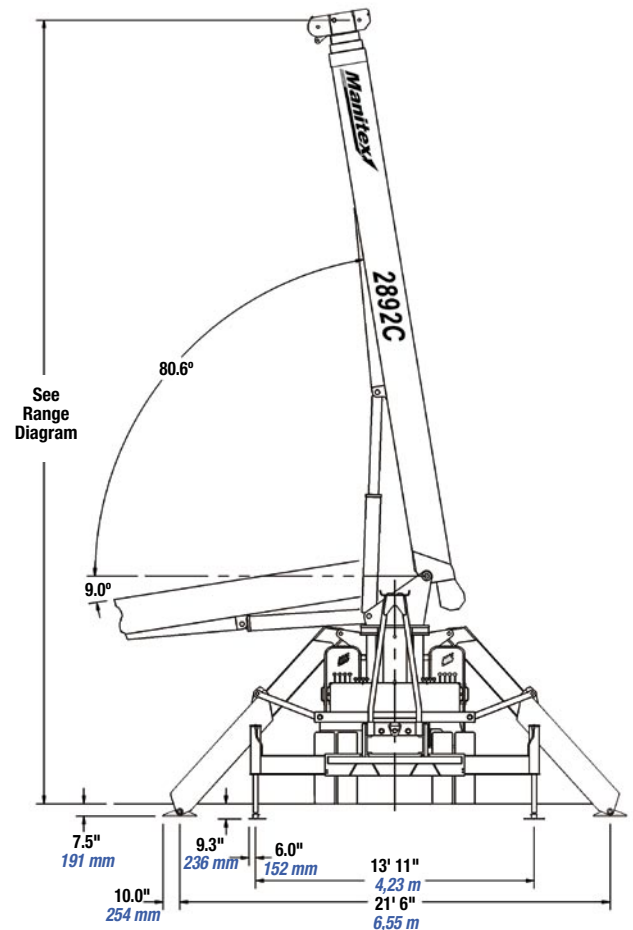

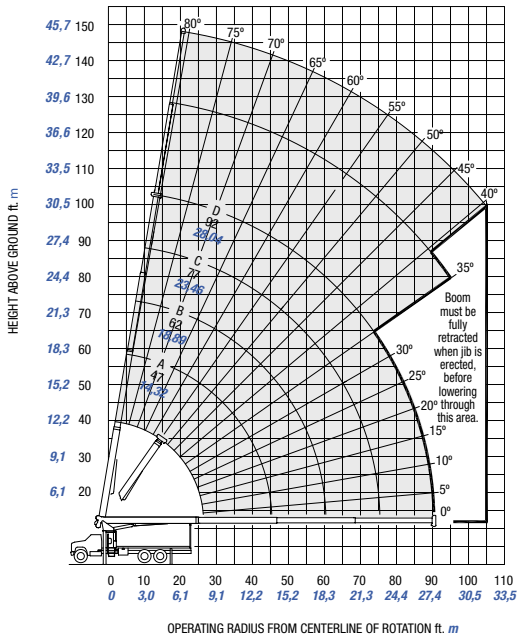

OUTRIGGER AND STABILIZERS EXTENDED: MODEL 2892 LMI

MAIN BOOM LOAD RATINGS

JIB LOAD RATINGS

Operating Radius	MAIN BOOM LOAD RATINGS												JIB LOAD RATINGS												
	Boom Length		A		B		C		D		Fixed Jib		Telescopic Jib												
	28 Feet 8,53 Meters	47 Feet 14,32 Meters	62 Feet 18,90 Meters	77 Feet 23,47 Meters	92 Feet 28,04 Meters	26 Feet 7,92 Meters	26 Feet 7,92 Meters	46 Feet 14,02 Meters																	
Feet Meters	∠ lb. kg.	∠ lb. kg.	∠ lb. kg.	∠ lb. kg.	∠ lb. kg.	∠ lb. kg.	∠ lb. kg.	∠ lb. kg.	∠ lb. kg.	∠ lb. kg.	∠ lb. kg.	∠ lb. kg.	∠ lb. kg.												
5	1.52	79	56000	25401																					
8	2.44	72	41560	18851																					
10	3.05	68	35030	15889	78	20500	9299																		
12	3.66	63	30330	13757	75	20500	9299	79	20500	9299															
15	4.57	56	25230	11444	71	20500	9299	77	20500	9299	80	15900	7212												
20	6.10	42	19300	8754	65	17780	8065	72	16780	7611	76	13540	6142	79	10200	4627									
25	7.62	21	13760	6241	58	14460	6559	67	13610	6173	73	11710	5312	76	9290	4214	79	5600	2540	79	5400	2449			
30	9.14				50	11810	5357	62	11390	5166	69	10160	4608	73	8330	3778	77	5300	2404	77	5100	2313	79	3400	1542
35	10.67				41	8800	3992	56	8960	4064	64	8830	4005	70	7320	3320	75	4960	2250	75	4700	2132	77	3300	1497
40	12.19				30	6800	3084	50	6950	3152	60	7040	3193	66	6460	2930	72	4490	2037	72	4230	1919	76	3200	1451
45	13.72				10	5350	2427	43	5530	2508	55	5610	2545	63	5660	2567	70	4080	1851	70	3820	1733	74	3040	1379
50	15.24							36	4460	2023	51	4540	2059	59	4590	2082	67	3710	1683	67	3440	1560	72	2800	1270
55	16.76							26	3620	1642	45	3710	1683	55	3760	1706	65	3380	1533	65	3100	1406	69	2630	1193
60	18.29							9	2940	1334	39	3050	1383	51	3100	1406	62	3080	1397	62	2810	1275	67	2480	1125
65	19.81										33	2500	1134	47	2550	1157	59	2690	1220	59	2400	1089	65	2310	1048
70	21.34										24	2050	930	42	2100	953	56	2230	1012	56	1940	880	63	2110	957
75	22.86										8	1650	748	36	1720	780	53	1850	839	53	1560	708	60	1940	880
80	24.38													30	1390	630	50	1510	685	50	1220	553	58	1680	762
85	25.91													22	1100	499	46	1230	558	46	940	426	55	1390	630
90	27.43													8	840	381	42	980	445	42	680	308	52	1140	517
95	28.96																38	750	340	38	460	209	49	910	413
100	30.48																						46	710	322
105	32.00																						43	530	240
			460	209		270	122		210	95		170	77		140	64	Deductions for stowed jib								
			690	313		410	186		310	141		250	113		210	95	Deductions for stowed telescopic jib								

Meets ANSI B30.5 Requirements - Do not operate crane or accessories within 10' (3,05 m) of live power lines.
 NOTICE: This chart is for reference only and must not be used for lifting purposes. Consult factory for other boom options.

AREA OF OPERATION

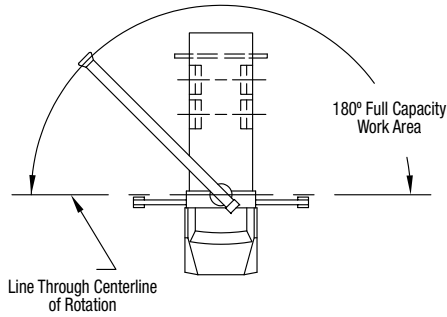

DEDUCTIONS

Auxiliary Block	50 lb 22.72 kg
Auxiliary Sheave	50 lb 22.72 kg
Overhaul Ball	See Overhaul Ball MFG. Nameplate
Load Block	See Block MFG. Nameplate
Hose Reel	140 lb 63.64 kg
Swing Around Jib	See Load Chart

ALLOWABLE LINE PULL

1 Part Line	2 Part Line	3 Part Line	4 Part Line	5 Part Line	6 Part Line	7 Part Line	WARNING
8,500 lb 3 856 kg	17,000 lb 7 711 kg	25,500 lb 11 567 kg	34,000 lb 15 422 kg	42,500 lb 19 278 kg	51,000 lb 23 134 kg	56,000 lb 25 402 kg	9/16" 6 x 25 IWRC (3.5:1 SF) - 29,750 lb min. breaking strength
7,400 lb 3 357 kg	14,800 lb 6 713 kg	22,200 lb 10 070 kg	29,600 lb 13 427 kg	37,000 lb 16 783 kg	44,400 lb 20 140 kg	51,800 lb 23 496 kg	9/16" rotation resistant (5.0:1 SF) - 37,000 lb min. breaking strength

BOOM AND JIB COMBINATIONS

2892C

92'

4-Section Boom

26' - 46' 2 - Section Jib



UPTime is the Manitex commitment to complete support of thousands of units working every day.

UPTime

- Includes 24-7-365 parts shipments.
- Utilizes the efficiency of UPNet online parts order system.
- Relies on Manitex's UPTrak support tracking system for performance analysis and resource allocation.
- Features REMan, Manitex's cost effective rebuild/exchange program.
- Provides expert service technicians for troubleshooting and site visits.
- Mandates training; at our facility and yours. It includes coordinated support from all component suppliers.
- Involves every Manitex team member in the support of every Manitex customer.

What does UPTime mean to Manitex customers?

UPTime means reliability.
UPTime means utilization.
UPTime means profitability.



Manitex
3000 South Austin Avenue
P.O. Box 1609
Georgetown, TX, USA 78627-1609
Telephone 512-942-3000
Facsimile 512-863-3776
www.manitex.com